

# Femto D4 & Atto D4

## Energy Analyzer

The **Femto D4** and **Atto D4** are respectively energy meters/analyzers and energy transducers/analyzers, extremely versatile and precise and microprocessor based. Designed to satisfy the most sophisticated applications for monitoring electrical parameters and managing energy in the civil, commercial and industrial sectors. Equipped with RS485 port, LED for active energy, indication of the phases sequence, 4 x operating time counters and firmware upgradeable remotely. Available in versions with digital inputs and / or digital or analogue outputs. Compliant with EN 50470-1 + EN 50470-3.



### True-RMS and accurate measurements

Measurements in true effective value (true-RMS), obtained by continuously sampling the waveforms of voltages and currents, and the automatic offset compensation of the internal amplifiers ensure maximum precision regardless of the variability of loads over time (ex. spot welders), from the signal level and the environmental operating conditions. The 64-bit resolution also ensures a high accuracy of the energy measurement even in the presence of small loads (e.g. equipment in stand-by).

### Simple to use

**Femto D4** is equipped with a graphic LCD display (dot matrix) with blue LED backlighting and adjustable contrast. Simultaneous reading of 4 measurements and their identification symbol with high visibility characters.



The 3-key keypad allows a simple and rational use of the instrument, while the page displayed at start-up can be defined by the user. On the front panel a configurable red LED for the calibration, pulses with a frequency proportional to energy.

### Versatility

**Femto D4** and **Atto D4** are suitable for applications on all types of network, three-phase 3-wire and 4-wire, symmetric or asymmetric, balanced or unbalanced, two-phase, single-phase, low and medium voltage, with 1, 2 or 3 CTs as well as for measurements on 2/4 quadrants (import / export). A keyboard programming allows you to set all the operating parameters such as RS485 port, network type, LV / ML, CT ratio and any VT (free value), integration time (1-60 min.) And depending on the version: analog and digital outputs, relay and alarm (thresholds, delay and hysteresis), analog and digital inputs. The programming system is password protected.

### Indication of the phases sequence

When the display is set to display the three phase voltages and the frequency, the indication of the phases sequence is also displayed, for example L123.

### EN 50470 and 62053-21 standards

The **Femto D4 & Atto D4** meet the essential requirements of the EN 50470-1 + 50470-3 standards as well as for the 62053-22 as required for White Energy Certificates normative.

### Readings

Parameter	Type	L1	L2	L3	n	Σ	P (8)	Range
Voltage	U <sub>L-N</sub>	•	•	•	•	•	•	20,0V...400 kV
	U <sub>L-L</sub>	•	•	•	•	•	•	
	U <sub>L-N</sub> MAX	•	•	•	•	•	•	
	U <sub>L-L</sub> MAX	•	•	•	•	•	•	
	U <sub>L-N</sub> MIN	•	•	•	•	•	•	
	U <sub>L-L</sub> MIN	•	•	•	•	•	•	
Current	I	•	•	•	•	•	•	10 mA...10,0 kA (ECT 10 mA...400A) F(7)[1A ... (5A - 500A)] [4A ... (20A - 2000A)] [8A ... (40A - 4000A)]
	I MAX	•	•	•	•	•	•	
	I <sub>AVG</sub> THERM (1)	•	•	•	•	•	•	
	I <sub>MD</sub> THERM (1)	•	•	•	•	•	•	
Power Factor	PF	•	•	•	•	•	•	0,00ind..1,00..0,00cap
Frequency	F	•	•	•	•	•	•	45 ... 65 Hz
Phases sequence	132 CCW	•	•	•	•	•	•	
Harmonic distortion	THD-U <sub>L-N</sub>	•	•	•	•	•	•	0...199,9%
	THD-U <sub>L-L</sub>	•	•	•	•	•	•	
	THD-I	•	•	•	•	•	•	
Active Power	P	•	•	•	•	•	•	± 0,00...1999 MW
	P <sub>AVG</sub> (2)	•	•	•	•	•	•	
	P <sub>MD</sub> (2)	•	•	•	•	•	•	
	P <sub>MAX</sub> (3)	•	•	•	•	•	•	
Reactive Power	Q <sub>IND</sub>	•	•	•	•	•	•	± 0,00...1999 Mvar
	Q <sub>CAP</sub>	•	•	•	•	•	•	
	Q <sub>AVG</sub> IND (2)	•	•	•	•	•	•	
	Q <sub>AVG</sub> CAP (2)	•	•	•	•	•	•	
	Q <sub>MD</sub> IND (2)	•	•	•	•	•	•	
	Q <sub>MD</sub> CAP (2)	•	•	•	•	•	•	
Apparent Power	S	•	•	•	•	•	•	± 0,00...1999 MVA
	S <sub>AVG</sub> (2)	•	•	•	•	•	•	
	S <sub>MD</sub> (2)	•	•	•	•	•	•	
Operating time (4)	h, h/100	•	•	•	•	•	•	0,01...99.999,99 h
Active Energy	E <sub>a</sub> IMP (5)	•	•	•	•	•	•	0,1 kWh...100 GWh
	E <sub>a</sub> EXP (5)	•	•	•	•	•	•	
Reactive Energy	E <sub>r</sub> IND IMP (5)	•	•	•	•	•	•	0,1 kvarh...100 Gvarh
	E <sub>r</sub> CAP IMP (5)	•	•	•	•	•	•	
	E <sub>r</sub> IND EXP (5)	•	•	•	•	•	•	
	E <sub>r</sub> CAP EXP (5)	•	•	•	•	•	•	
Apparent Energy	E <sub>s</sub> IMP (5)	•	•	•	•	•	•	0,1kVAh...100 GVAh
	E <sub>s</sub> EXP (5)	•	•	•	•	•	•	
Pulse Counter	CNT (6)	•	•	•	•	•	•	

All the instantaneous measurements are calculated on 10 cycles, for e.g. 200mS at 50Hz

- (1) Average values on integration time (1..60 min programmable) and peak (MD).
- (2) Average values (moving average) both in Import and in Export on the integration time (1..60 min programmable) and peaks (MD) or the maximum average value.
- (3) Maximum power values in both Import and Export.
- (4) Non-resettable life time and four partial operating time counters.
- (5) The energies (which consider the CT ratio) in both Import and Export are displayed as 9 digits (one decimal). The internal counters are stored in 64-bit resolution which ensures a minimum definition of 0.1 Wh and a maximum count of 100 GWh.
- (6) Only for versions with digital inputs.
- (7) For use with Electrex Flex CT – primary value as listed
- (8) Three partial counters for each measurement marked in column P.

### Serial port communication

The **Femto** and **Atto** are equipped, as a standard feature in all types, with an RS485 serial port with overvoltage protection. The communication protocol used is the "full compliant" Modbus-RTU suitable for communications with PLC and SCADA programs. The processed data are read as numeric registers composed of mantissa and exponent in IEEE format. A transmission up to 38.400bps with max. 125 registers that can be requested per each query (equal to about 62 parameters) without waiting times between two requests ensure an unrivalled communication speed.

### Types and versions of Femto D4 and Atto D4

The **Femto D4** and **Atto D4** are available in different types (and versions):

- **Femto D4 and Atto D4** using any CT  $\dots/5A$  or  $\dots/1A$  (standard type);
- **Femto D4 ECT and Atto D4 ECT** using Electrex ECT series type CT, mA output (to be ordered separately). Possibility to choose between 2 current full scales to increase the accuracy of the instrument in case of small currents – zoom effect;
- **Femto D4 F** using flexible CT - FCTS (Rogowski) series - in case the standard split CT cannot be used.
- **Femto MID D4 ECT** MID certificated, using ECT type CT with mA output (to be ordered separately). Possibility to choose between 2 current full scales to increase the accuracy of the instrument in case of small currents – zoom effect.

### Versions:

- **Standard**..... no inputs and outputs
- **2AO4-20mA**.....2 analog 4-20mA outputs (external power supply needed for resistance > 250 ohm)
- **4DI 4COMMON**..... 4 digital inputs with dedicated common terminals
- **4DO 4COMMON**..... 4 digital outputs with dedicated common terminals
- **2DI 2DO 4COMMON** . 2 digital inputs and 2 digital outputs .....with dedicated common terminals

### ECT series current transformers

- **ECT TA 100A 13MM Power Quality Current Transformer** Code PFAE000-01: closed ring CT for AC loads up to 100A. Plastic shield. Inner diameter 13 mm.
- **ECT CTS 16-100A Split Core Power Quality Current Transformer** Code PFAE000-02: split core CT for AC loads up to 100A. Plastic shield. Protection on the opening of the secondary circuit. Equipped with a snap-on closing, screwless mounting system. Inner diameter 16 mm.
- **ECT CTS 17-200A Split Core Power Quality Current Transformer** Code PFAE000-03: same as above but for loads up to 200A and inner diameter of 17 mm.
- **ECT CTS 36-400A and CTS 23,4-300A Split Core Power Quality Current Transformer** Code PFAE000-04 / ..06: split core CT for AC loads up to 400A. Inner window 35,9x35,9mm and 23,4x23,4 mm.



### Short-Circuitable Terminal Box

For short-circuiting the ECT type CT,  $\dots/1A$  or  $\dots/5A$  when not connected to the device but mounted on cables with load. Screw typw terminals for max cross section 1,5 mm<sup>2</sup> cables.

### The Femto D4 F using Electrex Flex CT (FCTS)

The **Femto D4 F** are equipped with dedicated current inputs exclusively for Electrex Flex CT series FCTS (mV output and on request calibration to specific device for more accuracy).

**WARNING:** Do not connect to these current inputs of CT with output in current (eg.  $\dots/1A$  or  $\dots/5A$ ) because it may damage both the Femto D4 F and the CT.

Selectable Full Scale independent from the internal diameter of the Flex CT used: 250A or 500A or or 1.000A or 2.000A or 4.000A.



- FCTS 070-500 Flexible split CT, internal diameter 7 cm
- FCTS 120-1000 Flexible split CT, internal diameter 12 cm
- FCTS 200-2000 Flexible split CT, internal diameter 20 cm
- FCTS 280-4000 Flexible split CT, internal diameter 28 cm.

### Femto MID D4 ECT

**Femto MID D4 ECT** and **Femto MID D4 ECT 2DI 2DO 4COMMON** including wired ECT 100A type CT are compliant with EN 50470-1 + EN 50470-3 standards and are suitable for being used in LV, 3 phase systems with 3 or 4 wires (Phase-Neutral 230V  $\pm 15\%$  and Phase - Phase 400V  $\pm 15\%$ ).

### Digital inputs

The versions **.. 1DI** or **2DI** or **4DI** are equipped with an optically insulated digital input complete with programmable filter for input glitches. The digital input is set to operate for external pulse count of, example, water meters, gas meters (insulation to meet the ATEX requirements), quantity count, etc. For the 1DI  $\dots$  or the 2DI 1RO the max sampling frequency is 100Hz (5ms), while for the 2DI 2DO and the 4DO 500Hz (1ms). Other user selectable operative modes are ON/OFF state input (example for reading the ON/OFF state of machines and switches) and tariff change input (example for day-night tariff changeover). The digital input requires an external 10-30Vdc power supply.

The versions **1DI 2DO Self-Powered** and **2DI 1RO Self-Powered** are equipped instead with self powered digital inputs.

### Digital outputs

The versions **.. 2DO** or **4DO** are equipped with two optically insulated transistor outputs rated 27 Vdc 27 mA according to DIN 43864 standards.

The version **1DI 2DO SELF-POWERED** instead is equipped with two opto-mos outputs rated at max 250V 100mA AC/DC.

The outputs may be set for the transmission of pulses or alternatively configured as outputs of the internal alarms (see Alarms) or as remote output modules controlled via serial line and Modbus commands.

### Alarms

The versions **.. 2DO** or **4DO** or **1RO** are equipped with outputs which can be related to the internal alarms. Each alarm can be linked to any one of the parameters available, for example, either as a minimum and/or as a maximum. All the alarm outputs can be linked to the same parameter in order to have more alarm thresholds. It is possible to set a delay on the activation / deactivation of each alarm (from 1s to 99 min), the hysteresis (% of the threshold value) and the polarity of the output contact (NA, NC, except for the **1RO** which is always NC). The alarms state information is always available on serial communication as Modbus "coils". Due to the numerous combinations available, only a part of them are programmable by keyboard while are entirely programmable via serial port with the Energy Brain software or via serial port using Modbus *Holding registers*.

### Analog 4-20mA outputs

The version **2AO4-20mA** are equipped with 2 galvanic insulated analogue outputs 4-20 mA or 0-20 mA providing an extremely high accuracy and signal stability. The outputs are active for resistor loads up to 250 ohm, for higher loads an external power supply (12Vdc) will be needed (up to 750 ohm). The outputs ensure a response time of max. 200 ms. Each output can be associated to any of the parameters.

### Power supply and Special versions on request

The **Femto D4** and **Atto D4** can also be requested in other hardware configurations such as with different power supply:

### Technical Specifications

#### Functional characteristics and Inputs / Outputs

Measurement system:

- True-RMS measurement up to the 31<sup>st</sup> harmonic
- 2 and 4 quadrant measurement (programmable)
- 12bit A/D converter (6-channel)
- Continuous sampling of voltage and current waveforms (64 sampling per period, with PLL)
- Automatic compensation of the offset and of the angle error of the current transformer.

RS485 serial port (Galvanically insulated) :

- 2.400 to 38.400 bps programmable speed
- Built-in over-voltage protection
- Modbus-RTU protocol, full compliant

Digital Input (depending on type):

- Galvanically insulated
- Programmable functionality: external pulse count, ON/OFF state detection, tariff changeover
- Programmable 10/100 Hz filter for input glitches (500Hz for versions 2DI 2DO and 4DI)
- External powered needed: ..... 10-30Vdc
- Current absorbed: ..... from 2 to 10mA or self-powered (Self-Powered version)

Digital Output (depending on type):

- Galvanically insulated
- Programmable functionality: weighted pulse output, alarm contact, remotely commanded
- NPN according to DIN 43864 (max 27Vdc, max 27mA)
- Or Self-Powered version with a solid state relay (opto-mos) ..... up to 250V 100mA ac/dc

Analog 4-20mA output (Galvanically insulated):

- Scale: ..... 0-20mA or 4-20mA (programmable)
- Update interval: ..... 200ms
- Max load resistance: ..... 250 ohm ..... (750 ohm with external power supply 12Vdc)
- Maximum current supplied: ..... 27 mA
- Accuracy: ..... 1% of the reading from 4 to 20mA

#### Front panel (Femto D4)

Display: graphic LCD with adjustable contrast  
 Femto D4 ..... 100x64 dots  
 visible area ..... 43x25 mm

Backlight: ..... yellow/green Led

Display update interval: ..... 1s

Keyboard: ..... 3 keys

Led: ..... 1 for Active Energy (10.000 pulses per kWh)

transformer type rated 115/120 Vac or 400Vac and switching type 15÷36Vac/18÷60Vdc and 9÷24Vac/9÷36Vdc. The **Femto MID D4** instead cannot be modified.

### Operating time counters

The **Femto** and **Atto** series display the life time of the instrument and are equipped with four operating time partial counters that can be activated by internal alarms through configuration via the Energy Brain software; for example, to manage the operating time of a user/machinery when it is operating, when it is in standby and when it is off. The partial operating time counters can be reset.

#### Electrical characteristics

Connection (**standard version**): single-, bi-phase & 3-phase, LT and MT systems, ... balanced, unbalanced, 3- and 4-wire, 1, 2 or 3 CT.

Voltage inputs:

Direct: ..... up to 300 Vrms phase-neutral or 519 Vrms phase-phase (300 Vrms if bi-phase)

Via external VTs:

Primary: ..... programmable (max. 400 kV)  
 Secondary: ..... programmable (max. 300 V)

Frequency: ..... 45÷65 Hz

Max voltage to ground: ..... 300 Vrms

Input burden: ..... < 0,3 VA

Input impedance ..... > 2 MΩ

Overload: ..... 900 Vrms phase-phase per 1 sec

Current Inputs (standard type):

with external CTs:

Primary: ..... programmable (max. 10 kA)

Secondary: ..... 1 or 5 A

Max current: ..... 1,2 or 6 Arms

Input burden: ..... < 0,7 VA

Overload: ..... 40 Arms, 1 sec.

Insertion (**ECT type**): single-, bi-phase & 3-phase, LT systems, .. balanced, unbalanced, 3- and 4-wire, 1, 2 or 3 CT

Voltage inputs:

Direct: ..... up to 300 Vrms phase-neutral or 519 Vrms phase-phase (300 Vrms if bi-phase)

Current Inputs with external CT ECT type:

Primary: ..... max. 400A

Secondary: ..... output in mA

Insertion (**F type - Rogowski**): ..... same as **standard type**

Voltage inputs : ..... same as **standard type**

Current Inputs with external split flexible CT FCTS type:

Primary: ..... 500A, 2.000A or 4.000A

Secondary: ..... output in mV

Power Supply (excluding Femto MID D4):

Standard version: ..... 230/240Vac +/- 10% 50/60Hz

Versions on request: ..... 115/120Vac +/- 10% 50/60Hz

400Vac +/- 10% 50/60Hz

15÷36Vac 50/60Hz, 18÷60Vdc

9÷24Vac 50/60Hz, 9÷36Vdc

Self consumption: ..... < 2,5VA

#### Accuracy

Voltage: ..... 0,25% of reading +/- 1 digit from 40 to 300V, min. reading: 10V

Current: ..... 0,25% of reading +/- 1 digit from 0,02 to 1,2A or from 1,2 to 6A, min. reading: 10mA

Frequency: ..... 0,02Hz from 45 to 65 Hz

Power: ..... 0,5% of reading +/- 1 digit

Active Energy: ..... Class 0,5S complying with IEC EN 62053-22 Class C according to EN 50470-3

Reactive Energy: ..... Class 1 complying with IEC EN 62053-24



**Standards**

General:..... EN 50470-1  
 Static counters :..... EN 50470-3  
 Safety:..... CEI EN 61010-1 CAT III-300V, class 2  
 E.M.C.:..... CEI EN 61326-1A  
 Accuracy:..... CEI EN 62053-22, EN 50470-1, EN 50470-3  
 Digital Outputs:..... DIN 43864  
 MTBF(100.000 hours):.....MIL-HDBK-217F

**Environmental conditions**

Working temperature range Femto D4:.....-25/+60 °C  
 Working temperature range Atto D4:.....-25/+70 °C  
 Storage temperature range:.....-30/+70 °C  
 Relative Humidity ..... 95% non-condensing

**Mechanical characteristics**

Enclosure .....Self-extinguishing plastic material class V0  
 Protection degree ..... Front panel ..... IP40  
 Terminals side.....IP20  
 Size: .....70 x 90.5 x 62 mm (4 DIN modules)  
 Terminals .....screw connector  
 Max cable size: ..... 2,5 mm<sup>2</sup> (stranded cable) /  
 4 mm<sup>2</sup> (solid cable)  
 Femto D4 weight: ..... about 315 g (packaging included)

**How to order - Femto D4**

Type	Code
Femto D4 RS485 230-240V .....	PFA6411-02-B
Femto D4 RS485 230-240V 1DI 2DO S.P.....	PFA6411-E2-B
Femto D4 RS485 230-240V 2AO4-20mA .....	PFA6411-62-B
Femto D4 RS485 230-240V 4DI 4COMMON .....	PFA6411-B2-B
Femto D4 RS485 230-240V 4DO 4COMMON .....	PFA6411-C2-B
Femto D4 RS485 230-240V 2DI 2DO 4COM. ....	PFA6411-D2-B
Femto D4 ECT RS485 230-240V .....	PFA6451-02-B
Femto D4 ECT RS485 230-240V 2AO4-20mA ...	PFA6451-62-B
Femto D4 ECT RS485 230-240V 4DI 4COM. ....	PFA6451-B2-B
Femto D4 ECT RS485 230-240V 4DO 4COM. ...	PFA6451-C2-B
Femto D4 ECT RS485 230-240V 2DI 2DO 4COMMON .....	PFA6451-D2-B
Femto D4 F RS485 230-240V .....	PFA64F1-02-C
Femto D4 F RS485 230-240V 2AO4-20mA .....	PFA64F1-62-C
Femto D4 F RS485 230-240V 4DI 4COMMON .	PFA64F1-B2-C
Femto D4 F RS485 230-240V 4DO 4COM. ....	PFA64F1-C2-C
Femto D4 F RS485 230-240V 2DI 2DO 4COMMON .....	PFA64F1-D2-C
Femto MID D4 ECT RS485 85-440V .....	PFA64M1-0A-B
Femto MID D4 ECT RS485 85-440V 2DI 2DO SG.....	PFA64M1-DA-B
ECT CT 100A 13MM (specific CT-not replaceable)	PFAE000-01
ECT CTS 16-100 (specific CT-not replaceable) ....	PFAE000-02
ECT CTS 17-200 (specific CT-not replaceable) ....	PFAE000-03
ECT CTS 52-400 (specific CT-not replaceable) ....	PFAE000-04
FCTS 070-500 Flex Split Current Transformer .....	PFCF021
FCTS 120-1000 Flex Split Current Transformer .....	PFCF022
FCTS 200-2000 Flex Split Current Transformer .....	PFCF023
FCTS 280-4000 Flex Split Current Transformer .....	PFCF024

**How to order - Atto D4**

Type	Code
Atto D4 RS485 230-240V .....	PFA7411-02-B
Atto D4 RS485 230-240V 2AO4-20mA .....	PFA7411-62-B
Atto D4 RS485 230-240V 4DI 4COMMON .....	PFA7411-B2-B
Atto D4 RS485 230-240V 4DO 4COMMON .....	PFA7411-C2-B
Atto D4 RS485 230-240V 2DI 2DO 4COMMON .....	PFA7411-D2-B
Atto D4 ECT RS485 230-240V .....	PFA7451-02-B
Atto D4 ECT RS485 230-240V 2AO4-20mA .....	PFA7451-62-B
Atto D4 ECT RS485 230-240V 4DI 4COM. ....	PFA7451-B2-B
Atto D4 ECT RS485 230-240V 4DO 4COM. ....	PFA7451-C2-B
Atto D4 ECT RS485 230-240V 2DI 2DO 4COM. ....	PFA7451-D2-B
Short-Circuitable Terminal Box .....	PCALM0-01

**Other versions of Femto D4 and Atto D4**

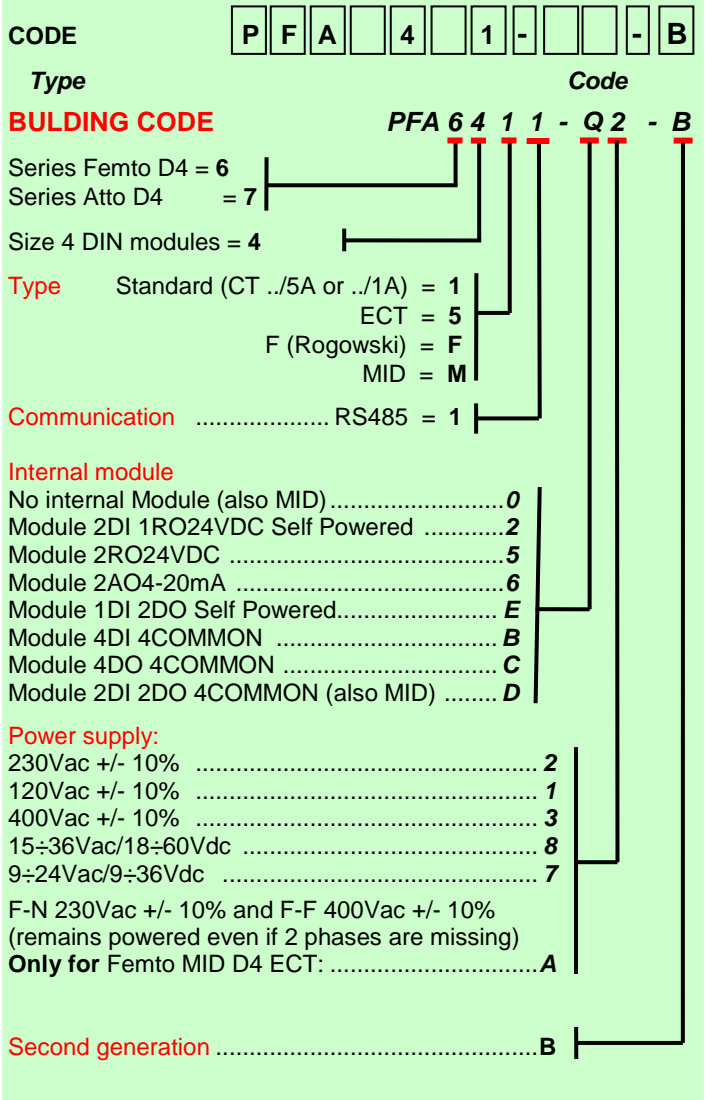

Subject to modification without prior notice  
 Data sheet Femto D4 and Atto D4 2020 12 08-ENG

Distributor